



Cat. No. 49-830

OWNER'S MANUAL

RS-3000 Auto Security Alarm System

Please read this entire manual *before* you begin installation.

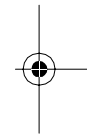
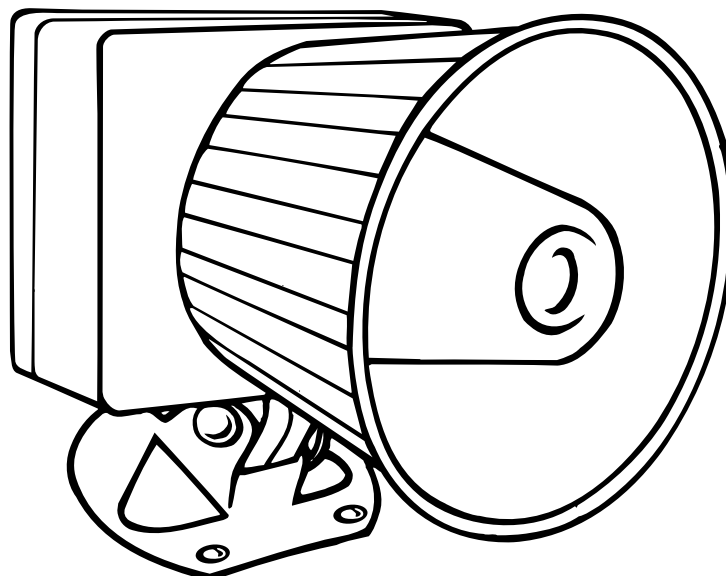

RadioShack™



FEATURES

Your RS-3000 Auto Security Alarm System's voice alert warns away potential thieves and alerts you to trouble in a clear, loud, male voice and shouts out a panic alert in a female voice. It also includes advanced features that help protect your vehicle from theft, yet you can install it in less than an hour. The two convenient key-chain transmitters lets you arm and disarm the system, sound a panic alert, or activate the car finder feature when you are away from your vehicle.

Your RS-3000 includes these features.

Note: The following features marked with an asterisk (*) might qualify you for a discount on your vehicle insurance premium. Show your insurance agent the supplied certificate.

Talking Alarm with 120 dB Alert — advises you of the alarm's status (armed or disarmed) and warns away potential thieves.

Piercing, 120 dB Siren — loud enough to be heard from hundreds of feet away.

Passive Arming — automatically arms the system after you exit the vehicle.

Starter Kill — prevents anyone from starting your vehicle when the system is armed.

Electronic Dual-Stage Shock Sensor — sounds a pre-alert warning the first time someone strikes your vehicle, then sounds the alert if it is hit again within 30 seconds.

Current Sensing System — triggers the alert when a door or trunk is opened and the vehicle's dome or trunk light turns on, or when your vehicle is hot wired, by sensing the current draw.

Current Sensor Bypass — lets you turn off current sensing if other electronic devices in your vehicle (such as a high-power audio system or cellular phone) make your alarm sound false alerts.

Status Indicator — mounted in plain view, lets you easily determine the status of the alarm system (armed or disarmed) and warns away potential thieves.

High Theft Alert Mode — lets you set the alarm to announce that it is armed or to chirp every 30 seconds.

Two Easy-to-Use Key-Chain Remotes — let you easily control your alarm from a distance.

Car Finder — lets you make the alarm sound beeps to help you find your vehicle in a crowded parking lot.

© 1997 Tandy Corporation.
All Rights Reserved.

RadioShack is a trademark used by Tandy Corporation.

Instant Panic Alarm — calls out in a female voice to alert others nearby that you need assistance when you are in or near your vehicle.

Valet Mode — lets you easily prevent passive arming when the vehicle is being serviced, valet parked, or washed.

Programmable Options — lets you customize several of your alarm's options.

Accessory Trigger Output — provides a negative trigger to activate (but not power) accessory sensors.

Violation Confirmation — beeps three times or says "I was tampered with!" when you disarm the system after the alarm has sounded, to let you know what happened while you were away from the vehicle.

Computer-Controlled Fan Sensor — can tell the difference between your vehicle's dome or trunk light and an electric cooling fan (which can make other alarms sound a false alert) without using additional wiring.

Toll-Free Help — if you have any questions about or problems with your alarm system, just call:

1-800-598-2527

Your system requires one 9-volt alkaline battery to maintain operation if the main power lead is disconnected.

Warning: Your alarm system's alerts are painfully loud. Take care during installation to keep your head away from the system once you connect power.

FCC INFORMATION

Your alarm system might cause TV or radio interference even when it is operating properly. To determine whether your system is causing the interference, move your vehicle out of the area. If the interference goes away, your alarm system was causing the interference. Try to eliminate the interference by:

- Keeping your system away from the receiver
- Contacting your local RadioShack store for help

If you cannot eliminate the interference, the FCC requires that you stop using your alarm system.

CONTENTS

Installing the System	5
Supplied Items	5
Installation Order	6
Connecting the Starter Disable Module	6
Connecting the System to Power	7
Activating the Remote Controls	8
Installing the Backup Battery	8
Mounting the System	9
Installing the Status Indicator	10
Using the Alarm System	11
Arming the Alarm	11
Temporarily Reducing the Shock Sensor's Sensitivity	11
High Theft Alert	11
Sounding the Panic Alarm	11
Alarm Violations	12
Disarming the System	12
Using the Car Finder	12
Setting the System's Options	13
Setting the Shock Sensor's Sensitivity	13
Setting the Current Sensor	13
Setting the Valet Mode (Passive Arming/Disarming)	14
Troubleshooting	15
Care and Maintenance	17
Replacing the Fuse	18
Replacing a Remote Control's Battery	18
Specifications	19

INSTALLING THE SYSTEM

SUPPLIED ITEMS

Your alarm system includes the following items:

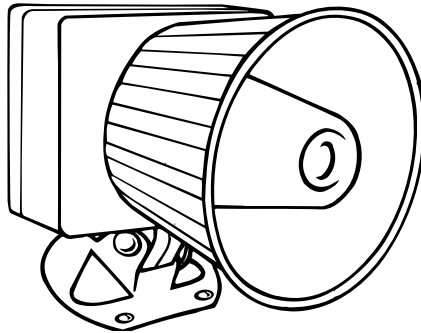

Main System

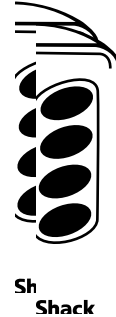

Shack

Two Four-Button Remotes

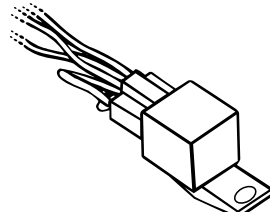

Starter Disable Relay



Mounting Screws

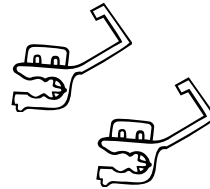

Wire Tap-In Connectors



Status Indicator with Bracket and Harness



Double-Sided Tape



Wire Ties

INSTALLATION ORDER

You can install your system in just 6 easy steps:

1. Connect the starter disable module.
2. Connect the system to power.
3. Train the remote controls.
4. Install the backup battery.
5. Mount the system.
6. Install the status indicator.

We recommend you get a wiring diagram for your vehicle before you begin, so you can easily find your vehicle's starter solenoid wire. Wiring diagrams are available from your vehicle's dealer or from the Auto Security Helpline at 1-800-598-2527.

You also need a 12-volt test lamp or DC voltmeter and a wire-piercing probe adapter (such as RadioShack Cat. No. 278-715) to ensure proper installation.

CONNECTING THE STARTER DISABLE MODULE

The starter disable module interrupts power to your vehicle's starter solenoid so the vehicle does not start when the system is armed. Follow these steps to connect the module.

1. Using the starter solenoid's color-coded wires as a guide, locate the wire that goes from your vehicle's ignition (key) switch to the solenoid. This wire is most easily found where the wires connect to the ignition switch near the steering column.
2. Connect the negative (usually black) lead from a 12-volt test lamp or DC voltmeter to a metal vehicle body part.
3. Connect the wire-piercing probe to the positive lead and press the pin tip through the solenoid wire's insulation and into the wire itself.
4. Start your vehicle. The test light should light or the meter should indicate voltage **only while the engine is cranking** (not while it is stopped or running).

If the test fails, repeat Steps 2–4 using a different wire until you find the correct one.

- Turn off the engine. Then cut the wire you located in Steps 2–4 at a point where there are several inches of wire on each side of the cut.

Note: After you cut this wire, you are unable to start your vehicle until you complete the installation.

- Use one of the supplied yellow wire tap-ins to connect the starter disable module's white wire to the wire going to the solenoid.

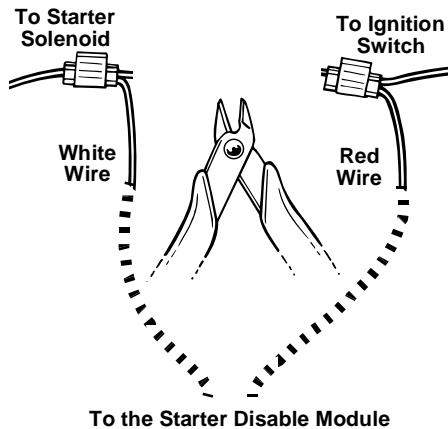

- Use the other yellow wire tap-in to connect the starter disable module's red wire to the wire going to the ignition switch.

- Route the main system's orange wire through an existing hole in the firewall, or drill a 1/4-inch hole in the firewall, taking care not to damage anything on the other side of the firewall. Then plug the starter disable module's orange wire into the main system's orange wire.

Note: If you drill a hole, use a rubber grommet to protect the wire from abrasion.

- Use a wire tie to secure the starter disable module under the dashboard.

CONNECTING THE SYSTEM TO POWER

Warning: We recommend that you muffle the alarm's speaker before you connect the system to power. The alarm is extremely loud.

Follow these steps to connect the system to power.

- Connect the system's red lead to your vehicle battery's positive (+) terminal.
- Connect the system's black lead to a metal part of the vehicle's body that is not insulated from the main chassis by a plastic part, or to the battery's negative (-) terminal. The system says "Thank you!"

ACTIVATING THE REMOTE CONTROLS

You must train the system to respond to the supplied remote controls. To activate both remote controls, immediately after applying power, press **ARM TALK** on one of the remotes. The system says "System Armed." Press **ARM TALK** again to disarm the system. The system says "System Disarmed."

If the system loses power and the backup battery is dead or not installed, the system stops responding to both remotes. Simply follow this procedure again to reactivate them.

Both of the supplied system remotes share the same remote code, but your system can learn two remote codes if you want to add another remote control (Cat. No. 49-845). To activate a second remote control code, be sure the system is disarmed, then hold down **ARM TALK** for 10 seconds. The system says "Thank You." Press any button on the new remote to activate it.

INSTALLING THE BACKUP BATTERY

A 9-volt battery (not supplied) powers your alarm if its main power is cut. Follow these steps to install the battery.

Note: For the best protection and longest life, we recommend you use an alkaline battery, such as RadioShack Cat. No. 23-553.

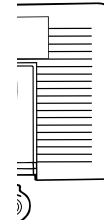

1. Slide off the compartment cover.
2. Snap a 9-volt battery onto the battery contacts.
3. Place the battery in the compartment.
4. Replace the compartment cover.

A new battery powers the alarm for about 21 hours with no alert, or 15 minutes of continuous alert. The alarm's volume is reduced when it is operating from the battery.

We recommend you replace the battery every 6 months, even if it has not been used to power the system.

MOUNTING THE SYSTEM

Select a location for your alarm system in the engine compartment. For the best results, the location should meet the following conditions.

- All wires should reach their connections without going near moving or hot engine parts.

Note: If necessary, you can extend the wires using hook-up wire and butt connectors. Use at least 18-gauge wire and an insulated wire connector to extend a wire.

- The mounting location should be solid and have no mechanisms or moving parts on its other side.
- For the best remote range, the mounting location should allow the system's yellow antenna wire to hang straight down. Do not cut or extend the wire — its length is optimized for best operation.
- For the loudest siren, the siren horn should point down toward the pavement.
- The alarm should not point straight up, as moisture could collect in the siren horn and damage the system.
- To prevent water damage, the system should not be mounted in a wheel well, directly behind the radiator grill, or close to the ground.

Once you select a location, follow these steps to mount the system.

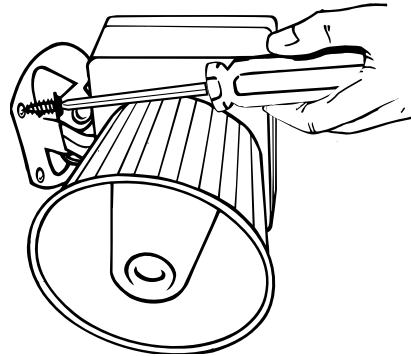

1. Hold the system against the selected location and mark the locations of the three mounting holes.
2. Drill 1/8-inch holes at the marked locations, taking care not to drill into anything behind the mounting surface.
3. Secure the system to the surface using the supplied screws.

Note: For the best shock-sensor operation use all three screws.

INSTALLING THE STATUS INDICATOR

The status indicator goes inside your vehicle's passenger compartment. Either drill a mounting hole in a dash panel or use the supplied mounting bracket to hold the indicator. Follow these steps to install the indicator.

1. Locate an existing wire harness that goes through your vehicle's firewall, and push the indicator into the passenger compartment through the existing hole.

If you cannot find an existing wire harness, drill a $\frac{1}{4}$ -inch hole through the firewall into the passenger compartment. Then push the indicator through the hole.

Cautions:

- Before drilling, be sure you can reach the other side of the hole.
- Do not drill into any mechanism on the other side of the firewall.
- Protect the wire by placing a rubber grommet (not supplied) in the hole, and route the wire through the grommet.

2. **If you are using the supplied mounting bracket**, use denatured alcohol to clean the mounting surface and let the surface dry completely. Peel the backing off of one side of the double-sided tape and press it onto the

bottom of the bracket. Then peel off the adhesive backing from the other side of the tape and press the bracket onto the dash.

If you are mounting the indicator in the dash, drill a $\frac{5}{16}$ -inch hole at the desired location.

3. Press the supplied grommet into the mounting hole from the front of the surface.

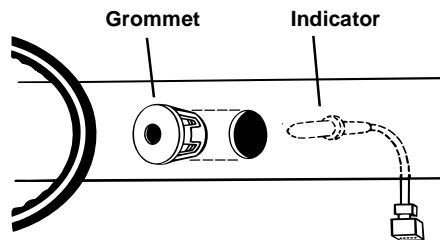

4. Press the indicator into the grommet from the back of the surface.
5. Plug the indicator's harness into the matching harness on the system.
6. Use the supplied wire tie to secure the wire out of the way.
7. If you drilled a hole in the firewall, use silicon sealant (not supplied) to waterproof the hole.

USING THE ALARM SYSTEM

ARMING THE ALARM

To arm the alarm in the voice mode, press **ARM TALK**. The alarm says "System Armed."

To arm the system in the chirp mode, press **ARM CHIRP**. The alarm chirps once.

Notes:

- The status indicator flashes when the system is armed.
- The system ignores current-sensing violations for 40 seconds after it arms.
- The system ignores shock-sensor violations for 8 seconds after it arms.
- If the valet mode is turned off, the system arms 60 seconds after you turn off your vehicle.

Temporarily Reducing the Shock Sensor's Sensitivity

If you are parking in a severe weather situation, near a construction zone, or near heavy traffic, you can temporarily reduce the system's shock sensor sensitivity to help prevent false alarms. To reduce the sensitivity to half its normal level, first press **ARM TALK** or **ARM CHIRP** to arm the system in the desired mode. Then, within 2 seconds, press the other **ARM** button (if you first pressed **ARM TALK**,

press **ARM CHIRP** to reduce sensitivity). The alarm says "Thank you."

To completely turn off the shock sensor, press the other **ARM** button twice within 2 seconds of arming. The alarm says "Thank you" each time you press the button.

When you disarm and rearm the system, the shock sensor returns to its previous sensitivity setting.

High Theft Alert

If you park your vehicle in a high-crime area, you can further protect your vehicle by having the alarm announce that it is protected every 30 seconds.

To turn on this feature, press **FINDER** within 2 seconds of arming. If you armed the system in the voice mode, the system says "System Armed" every 30 seconds. If you armed the system in the chirp mode, the system chirps twice every 30 seconds.

SOUNDING THE PANIC ALARM

To sound a panic alarm, press and release **PANIC**. The alarm screams "Please help me!" and sounds loud tones for 30 seconds. Press any button to stop the panic alarm sooner.

ALARM VIOLATIONS

Your alarm senses violations by monitoring your vehicle's electrical system (current sensing) and by detecting impacts (shock sensing).

An alert sounds immediately if the current sensor detects an electrical drain such as occurs when a dome or trunk light turns on.

The first time the alarm senses an impact that exceeds its sensitivity level, it says "You are too close to the vehicle. Please, move away" (if armed in the voice mode) or chirps 3 times (if armed in the chirp mode). If it senses another impact within 30 seconds, the system sounds a full alert.

Note: If an impact is severe, a single impact can cause a full alert to sound, without giving a warning.

When your alarm senses a violation, it sounds an alert for 30 seconds. If you armed the system in the voice mode, it yells "I was tampered with" and sounds loud tones. If you armed the system in the chirp mode, the system sounds loud tones. To silence the alert sooner, press any button.

DISARMING THE SYSTEM

To disarm the system, press either **ARM TALK** or **ARM CHIRP**. The system confirms that it is disarmed by saying "System disarmed" or by beeping twice.

Notes:

- The status indicator is off when the system is disarmed.
- If the valet mode is turned off, the system rearms itself after 1 minute if you have not started the vehicle.
- If the system detected a violation while you were away, it says "I was tampered with" or beeps three times when you disarm it.

USING THE CAR FINDER

The car finder helps you find your vehicle in a dark or crowded parking lot. To use the car finder, with the system armed, press **FINDER**. The alarm chirps 8 times.

SETTING THE SYSTEM'S OPTIONS

You can adjust the following options:

- Shock Sensor Sensitivity
- Current Sensor (On/Off)
- Valet Mode (On/Off)

Setting the Shock Sensor's Sensitivity

The shock sensor's initial setting is fine for most situations. To test the shock sensor, strike your vehicle on the hood directly over the alarm.

If the shock sensor is too sensitive or not sensitive enough, follow these steps to set it to a different level.

1. With the alarm disarmed, hold down **FINDER** until the alarm says "Please adjust sensor now."
2. Within 2 seconds, strike your vehicle with as much force as you want the alarm to respond to. The alarm responds with "Thank you." Any shock equal to or greater than the setting triggers the alert.

Notes:

- If you do not strike your vehicle within 2 seconds, the alarm is set to its highest sensitivity. This could cause frequent false alerts.
- The shock sensor does not operate for 8 seconds after you arm the system.

Setting the Current Sensor

If your vehicle has electronic accessories that turn on and off automatically while you are away from the vehicle, the alarm might sound false alerts. (The system can detect an electric engine fan, and does not sound a false alert when the fan comes on.)

To disable the current sensor so accessories do not trigger an alert, disarm the system. Then hold down **PANIC** for about 2 seconds. The system chirps twice.

To re-enable the current sensor, with the system disarmed, hold down **PANIC** for about 2 seconds. The system chirps once.

Notes:

- The current sensor does not operate for 40 seconds after the system arms.
- You can also try unplugging or disconnecting electronic accessories such as radar detectors or cellular phones when you leave your vehicle, instead of disabling the current sensor, to prevent the false alerts.

Setting the Valet Mode (Passive Arming/Disarming)

The valet mode lets you leave your vehicle for service or with a valet and *not* have it arm 60 seconds after you turn off the engine. The default is for the valet mode to be on (passive arming is off).

To have your system automatically arm 60 seconds after you turn off the engine, hold down **ARM CHIRP** for about 10 seconds. The system says "System Armed."

To turn on the valet mode (so the system does not passively arm), hold down **ARM CHIRP** again for about 10 seconds. The system says "System Disarmed."

TROUBLESHOOTING

This section describes some problems you might encounter and gives possible solutions.

Problem	Possible Solution
Frequent false alerts	<ul style="list-style-type: none"> • Another accessory is triggering the alarm. Try turning off current sensing to see if this solves the problem. If it does, try turning it back on, then removing other accessories, one by one, until you find which accessory is triggering the false alert. If possible, turn off that accessory when you leave your vehicle. Common problem accessories are cellular phones, radar detectors, and vehicle self-test systems. If you cannot turn off the accessory, leave current sensing disabled. <p>Note: Your alarm can tell the difference between the vehicle's electric fan and other accessories, so the fan does not trigger a false alert if the fan turns on while the system is armed.</p> <ul style="list-style-type: none"> • Your alarm's electrical connections are not making good contact. Check the connections and, if necessary, connect the power and ground leads to the vehicle's battery terminals. • The shock sensor is too sensitive. See "Setting the Shock Sensor's Sensitivity" on Page 13 to change the sensor's setting. • Loud thunderclaps and heavy machinery can trigger a false alarm. If you know a thunderstorm is approaching or that heavy machinery will be used nearby you can temporarily reduce the shock sensor's sensitivity or turn it off entirely. See "Temporarily Reducing the Shock Sensor's Sensitivity" on Page 11.
The alarm is not loud enough	<ul style="list-style-type: none"> • The system is operating from its backup battery. Check all power connections. • The siren is being muffled by the engine or hood. Try repositioning the siren so it points to the pavement.

Problem	Possible Solution
Alarm does not operate	<ul style="list-style-type: none">• Check all power connections.• Check the system's fuse. If it has blown, see "Replacing the Fuse" on Page 18.• Check the remote control's battery. See "Replacing a Remote Control's Battery" on Page 18.
Alarm does not sound when it should	<ul style="list-style-type: none">• The shock sensor is not sensitive enough. See "Setting the Shock Sensor's Sensitivity" on Page 13. If you set the shock sensor to its maximum sensitivity and the alarm still does not sound, confirm that you mounted the alarm on a solid, metal vehicle part (not on the frame or on rubber or plastic parts). If necessary, reposition the alarm for better performance.• If you have a large vehicle, the shock sensor might not detect impacts on parts of the vehicle far from the system. Remember that most thieves break into your vehicle through one of the front doors or windows. If you set the system sensitive enough to detect all impacts, you might experience frequent and annoying false alarms.• Confirm that you have not accidentally disabled current sensing. See "Setting the Current Sensor" on Page 13.
The remote control's range is poor	<ul style="list-style-type: none">• The antenna wire is too close to metal. If possible, position the yellow antenna wire away from metal.• The antenna wire has been cut or extended. The antenna wire is factory tuned for the best performance (a longer antenna actually does not work as well as the short included antenna wire). If the wire has been cut, take the system to your local RadioShack store for repair service.

CARE AND MAINTENANCE

Your RadioShack RS-3000 Auto Security Alarm System is an example of superior design and craftsmanship. The following suggestions will help you care for the alarm so you can enjoy its protection for years.



Keep the remote controls dry. If they get wet, wipe them dry immediately. Liquids can contain minerals that might corrode the electronic circuits.



Handle the alarm and remotes gently and carefully. Dropping them can damage circuit boards and cases and might make the remotes work improperly.



Use and store the remote controls only in normal temperature environments. Temperature extremes can shorten the life of electronic devices, damage batteries, and distort or melt plastic parts.



Keep the remote controls away from dust and dirt, which can cause premature wear of parts.



Do not use harsh chemicals, cleaning solvents, or strong detergents to clean the alarm.



Use only fresh batteries of the recommended size and type in your alarm and remote controls. Old or weak batteries can leak chemicals that can damage your system's internal circuits.

Modifying or tampering with your alarm's internal components can cause a malfunction and might invalidate the alarm's warranty and void your FCC authorization to operate it. If your alarm is not operating as it should, take it to your local RadioShack store for assistance.

REPLACING THE FUSE

Follow these steps to check the system's fuse and replace it if it has blown. The system uses a 5-amp $1\frac{1}{4}$ × $\frac{1}{4}$ -inch fast-acting fuse (Cat. No. 270-1011).

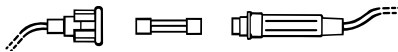

1. Push together the two halves of the inline fuse holder (on the red power wire) and twist them to separate the halves.
2. Inspect the fuse. If the wire is broken or not there, replace it.

Caution: Use only a fuse of the same type and rating. Using a different type of fuse or bypassing the fuse protection can damage your alarm or your vehicle's electrical system.

3. Put the new fuse in the holder and push and twist the holder's halves together.

REPLACING A REMOTE CONTROL'S BATTERY

If your remote control's range is reduced or if the indicator does not light when you press a button, replace its battery. Each remote control uses a 12-volt remote control battery (Cat. No. 23-144). Follow these steps to replace the battery.

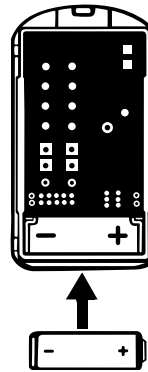

1. Snap apart the remote control's case.

Caution: Take care not to lose any of the remote control's pieces.

2. Replace the battery with a new one.
3. Put all parts back in place and snap the case halves back together.

SPECIFICATIONS

Siren Sound Level	More than 120 dB at 1 Meter
Current Drain	22 mA (Standby) 1 Amp (Siren Sounding)
Power Requirements	9–16 Volts DC
Alarm Weight	1 lb, 8 oz
Remote Carrier Frequency	303.875 MHz
RF Output Power	5,580 μ V at 1 Meter
Remote Control Power	12-Volt Alkaline Battery
Remote Weight	1.5 oz

Specifications are typical; individual units might vary. Specifications are subject to change and improvement without notice.

Limited Ninety-Day Warranty

This product is warranted by RadioShack against manufacturing defects in material and workmanship under normal use for ninety (90) days from the date of purchase from RadioShack company-owned stores and authorized RadioShack franchisees and dealers. In the event of a product defect during the warranty period, take the product and the RadioShack sales receipt as proof of purchase date to any RadioShack store. RadioShack will, at its option, unless otherwise provided by law: (a) correct the defect by product repair without charge for parts and labor; (b) replace the product with one of the same or similar design; or (c) refund the purchase price. All replaced parts and products, and products on which a refund is made, become the property of RadioShack. New or reconditioned parts and products may be used in the performance of warranty service. Repaired or replaced parts and products are warranted for the remainder of the original warranty period. You will be charged for repair or replacement of the product made after the expiration of the warranty period.

This warranty does not cover: (a) damage or failure caused by or attributable to acts of God, abuse, accident, misuse, improper or abnormal usage, failure to follow instructions, improper installation or maintenance, alteration, lightning or other incidence of excess voltage or current; (b) any repairs other than those provided by a RadioShack Authorized Service Facility; (c) consumables such as fuses or batteries; (d) cosmetic damage; (e) transportation, shipping or insurance costs; or (f) costs of product removal, installation, set-up service adjustment or reinstallation.

EXCEPT AS PROVIDED HEREIN, RadioShack MAKES NO EXPRESS WARRANTIES AND ANY IMPLIED WARRANTIES, INCLUDING THOSE OF MERCHANTABILITY AND FITNESS FOR A PARTICULAR PURPOSE, ARE LIMITED IN DURATION TO THE DURATION OF THE WRITTEN LIMITED WARRANTIES CONTAINED HEREIN. EXCEPT AS PROVIDED HEREIN, RadioShack SHALL HAVE NO LIABILITY OR RESPONSIBILITY TO CUSTOMER OR ANY OTHER PERSON OR ENTITY WITH RESPECT TO ANY LIABILITY, LOSS OR DAMAGE CAUSED DIRECTLY OR INDIRECTLY BY USE OR PERFORMANCE OF THE PRODUCT OR ARISING OUT OF ANY BREACH OF THIS WARRANTY, INCLUDING, BUT NOT LIMITED TO, ANY DAMAGES RESULTING FROM INCONVENIENCE, LOSS OF TIME, DATA, PROPERTY, REVENUE, OR PROFIT OR ANY INDIRECT, SPECIAL, INCIDENTAL, OR CONSEQUENTIAL DAMAGES, EVEN IF RadioShack HAS BEEN ADVISED OF THE POSSIBILITY OF SUCH DAMAGES.

Some states do not allow the limitations on how long an implied warranty lasts or the exclusion of incidental or consequential damages, so the above limitations or exclusions may not apply to you. This warranty gives you specific legal rights, and you may also have other rights which vary from state to state.

RadioShack Customer Relations, Dept. W, 100 Throckmorton St., Suite 600, Fort Worth, TX 76102

We Service What We Sell

1/97

RadioShack
A Division of Tandy Corporation
Fort Worth, Texas 76102